



Modeling of integrated urban wastewater systems

Lorenzo Benedetti

WATERWAYS



RECAST UWWTD: KEY DRIVERS

***DIRECTIVE (EU) 2024/3019 — IN FORCE 1 JANUARY 2025,
REPLACES 91/271/EE***

- First major update since 1991; transposition by **31 July 2027**
- Scope expanded to agglomerations **≥1,000 p.e.** (was 2,000)
- Three newly addressed sources: storm/CSO overflows, individual systems, small agglomerations
- New **4th treatment stage** (quaternary) for micropollutant removal: ≥80% removal required
- **Extended Producer Responsibility:** pharma & cosmetics fund ≥80% of quaternary costs
- Mandatory monitoring: PFAS, microplastics, AMR, emerging pathogens



TREATMENT OBLIGATIONS AND DEADLINES

TREATMENT LEVEL	THRESHOLD	DEADLINE
Secondary	≥1,000 p.e.	2035
Tertiary (N/P)	≥150,000 p.e. / ≥10,000 p.e.	2039 / 2045
Quaternary (micropollutants)	≥150,000 p.e. (20% → 60% → 100%)	2033 / 2039 / 2045
Quaternary — risk-based	≥10,000 p.e., sensitive receiving waters	2045
Energy neutrality	≥10,000 p.e.	2045
Integrated WWMP	≥100,000 p.e. / ≥10,000 p.e. risk-based	2033 / 2039



MODELLING THE WASTEWATER CATCHMENT

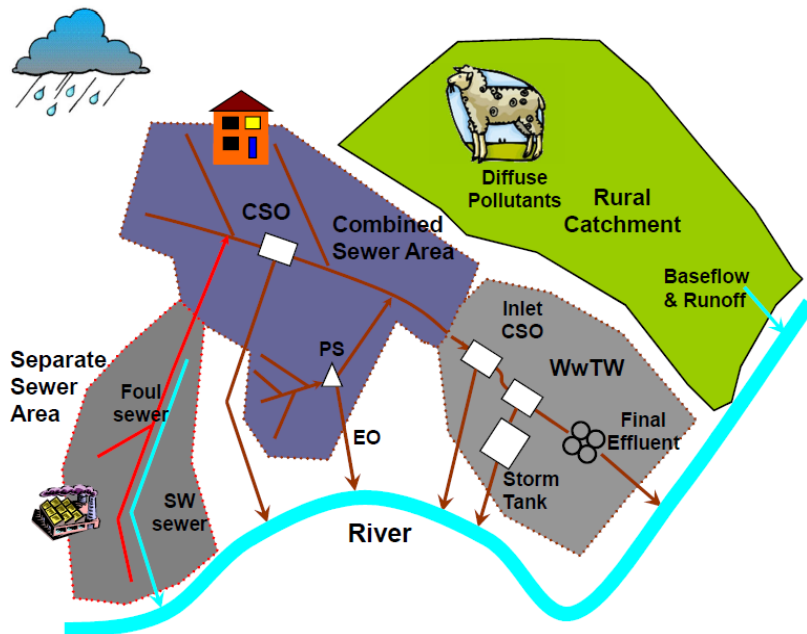

Continuous

- Rural runoff & baseflow
- WRRF final effluent

Intermittent (wet weather)

- Combined Sewer Overflow (CSO)
- Stormwater sewer
- WRRF storm tanks
- WRRF final effluent



Integrated Model

Calibrated + Validated Surrogate Sub-Models

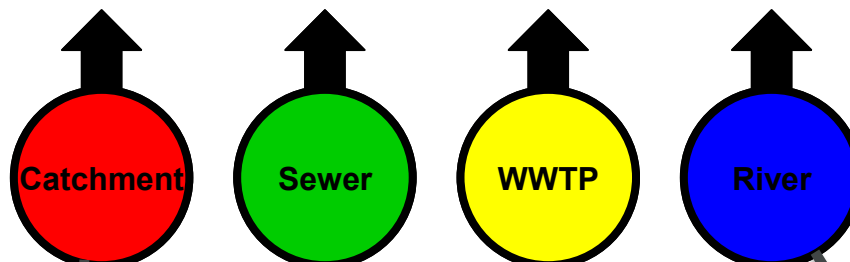
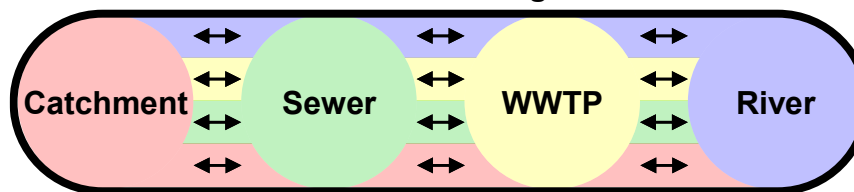

Separate detailed (slow) models

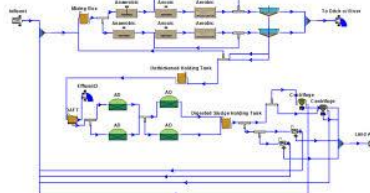
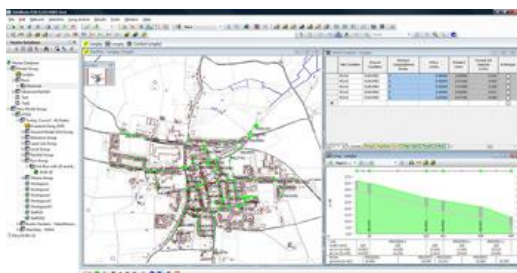



INTEGRATION – SINGLE PLATFORM (DYNAMITA SUMO)

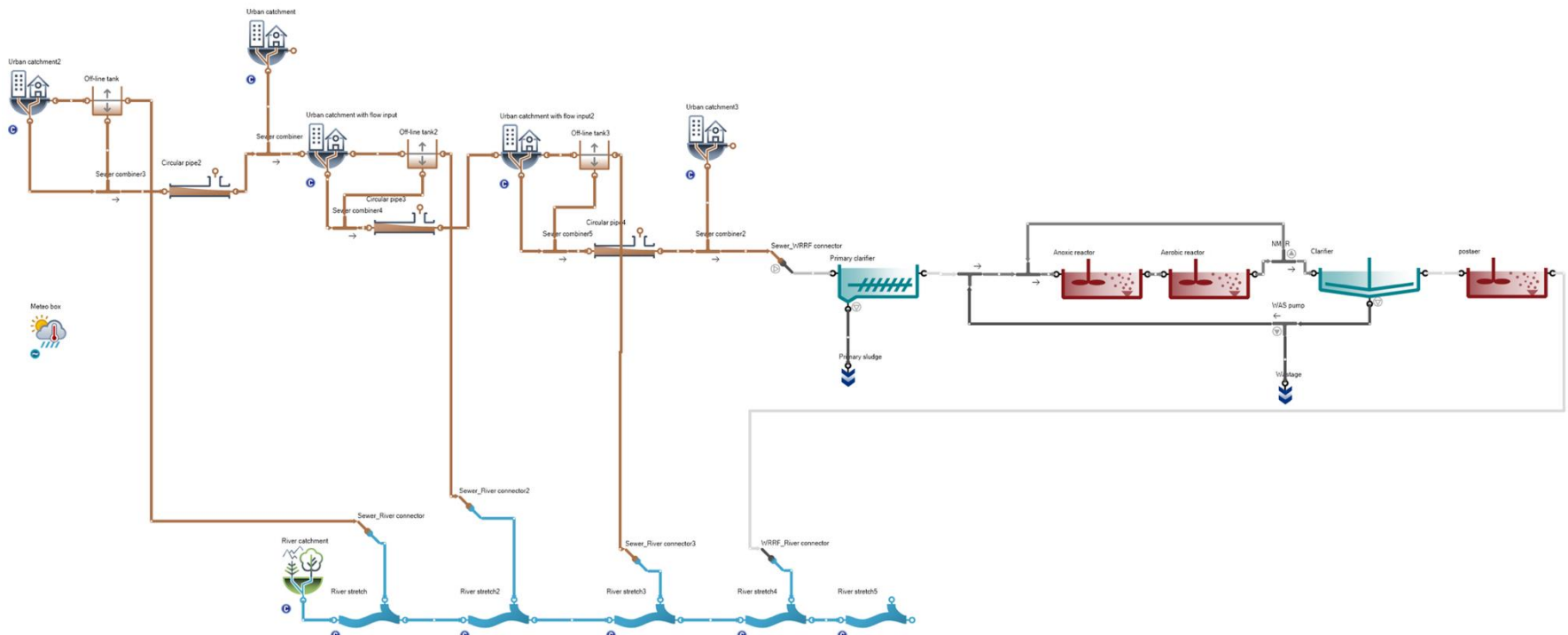

INTEGRATION – SINGLE PLATFORM (DHI WEST)

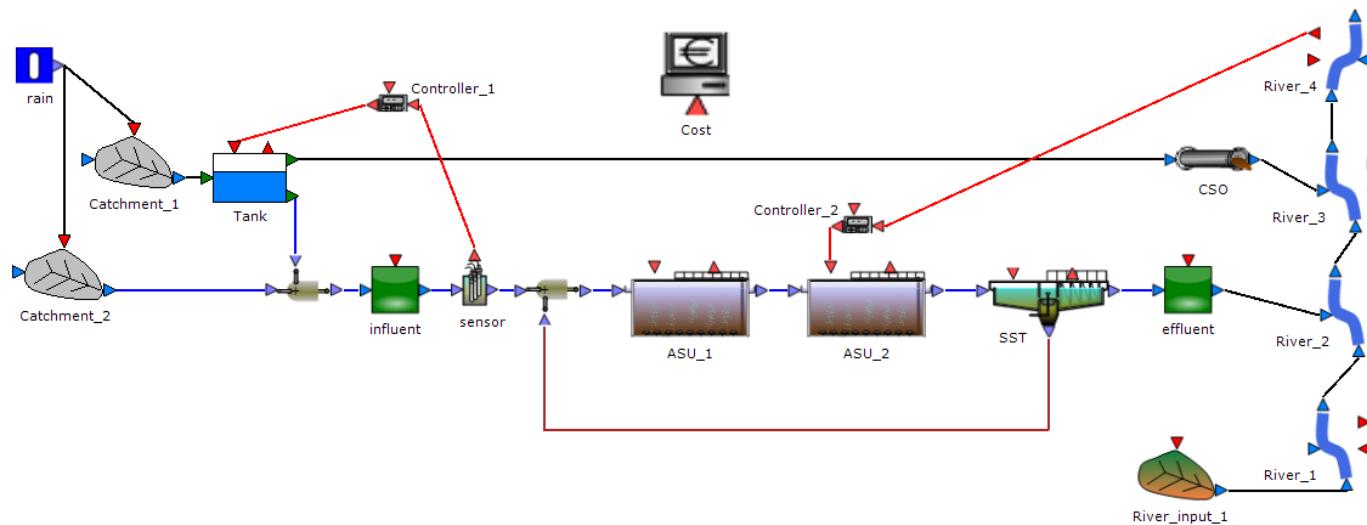



WHAT TYPE OF QUESTIONS CAN IUWS MODELS ANSWER?

- What sewer and WRRF operating strategies might be the most effective in wet weather conditions?
- What are the impacts of planned upgrades of collection systems on the WRRF?
 - Surface decoupling, green infrastructure, retention volumes, RTC, infiltration reduction, residential and industrial developments...
- What is the actual effect of CSOs on river quality?
- What will be the impact of climate change?
- *Communication tool between departments and entities*
- *Integrated Urban Wastewater Management Plans (EU UWWTD)*

ODENSE



3rd largest city in Denmark

Ca. 192 000 inhabitants

Birth place of H.C. Andersen





ODENSE WET WEATHER CHALLENGES I: 150+ CSOS & 80+ STORM WATER OUTFALLS

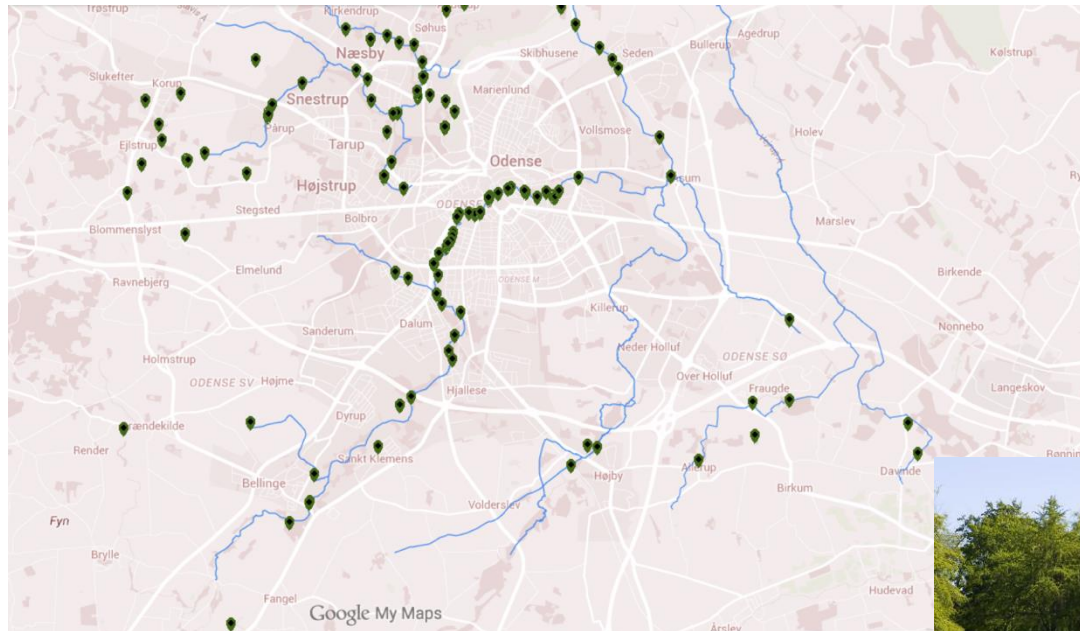

ODENSE WET WEATHER CHALLENGES II: 3 WWTPS

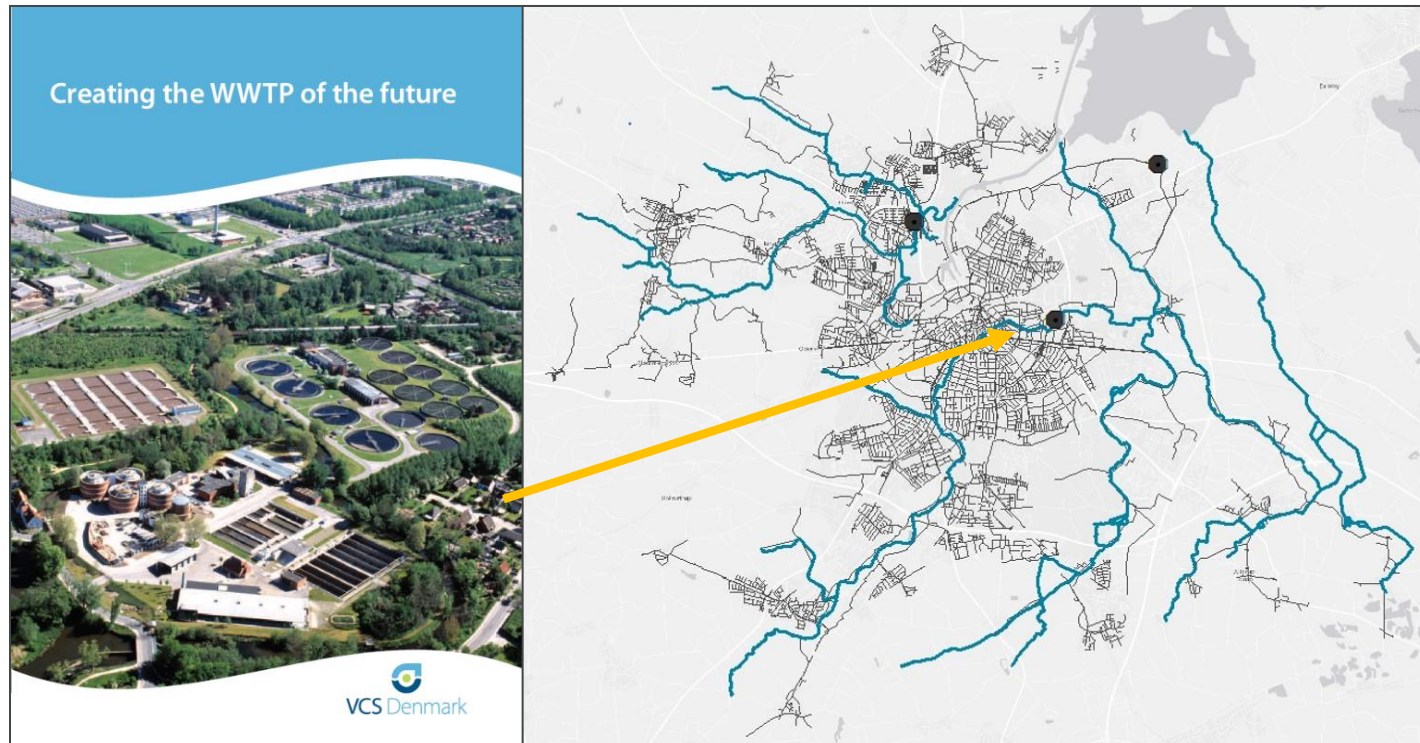



ODENSE WET WEATHER CHALLENGES III: REGULATION AND PLANNING APPROACH

Regulator's approach to wet weather permitting

- Separate consideration of CSO and WRRF
- Annual CSO discharge volume (250m³/ha)
- Annual CSO discharge frequency (< 5)

1. Different regulator agreement
2. Recognise collection system & WRRF interactions
3. CSO & WRRF impacts on river quality
4. A quantitative tool

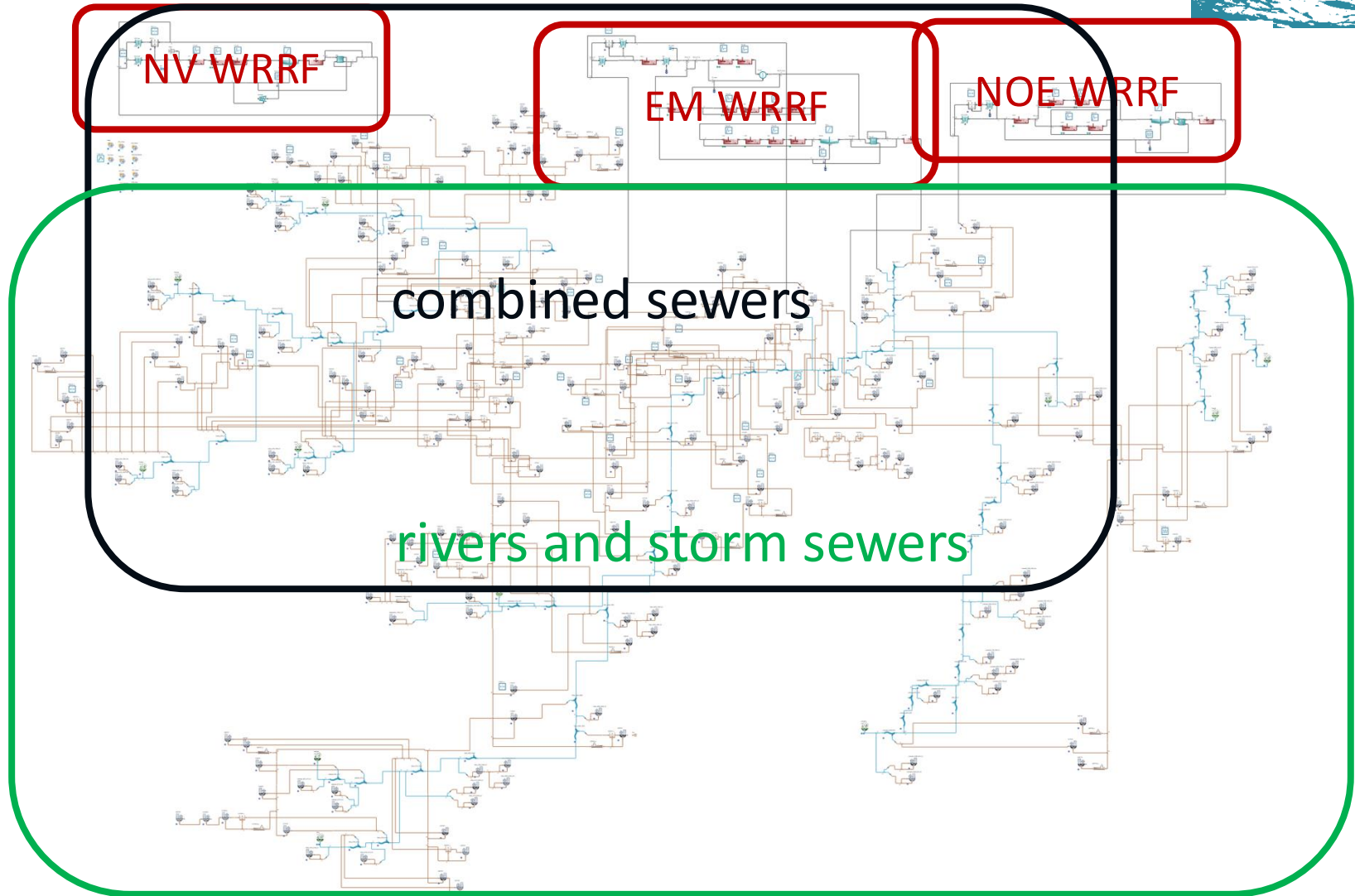



EXAMPLES OF SCENARIOS

- Scenario 1 (**storage**) proposed by the **Regulator**:
 - 9000 m³ of additional CSO storage volume at 9 locations
 - 3 upgraded pumping capacities (additional 60 l/s) at CSO structures
 - More expensive
- Scenario 2 (**pumping**) proposed by the **Utility**:
 - 700 m³ of additional volume at one CSO location
 - 9 upgraded pumping capacities (additional 500 l/s) at CSO structures
 - 2 new pumping stations (1000 and 500 l/s)
 - a new scheme to accept higher wet-weather flows at the NV WRRF
 - Less expensive
 - Better against flooding



NV WWTP (FINAL) EFFLUENT LOADS

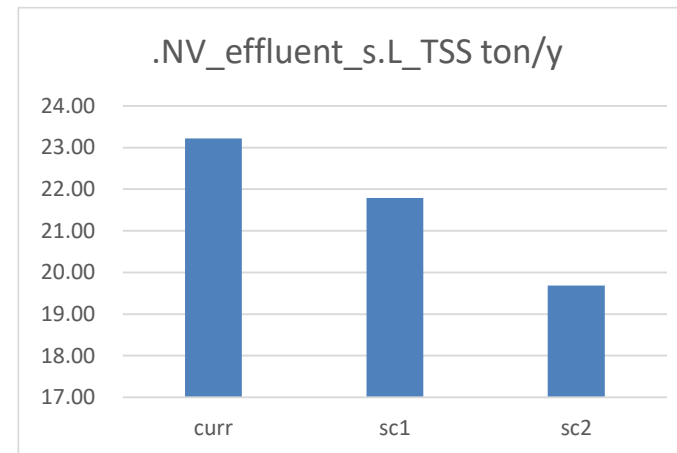
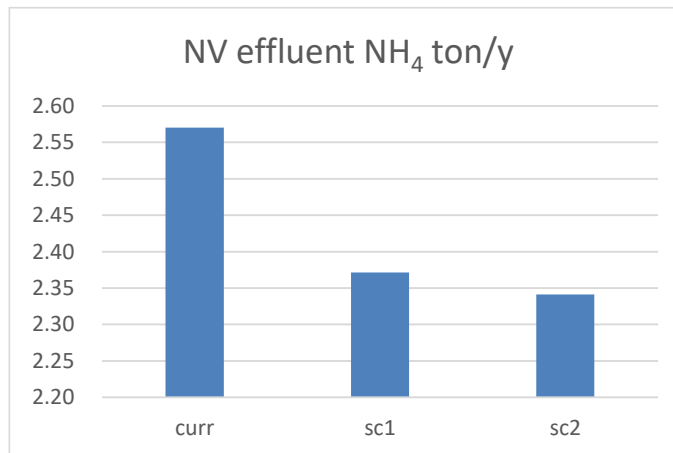



CSOS VOLUME AND LOAD

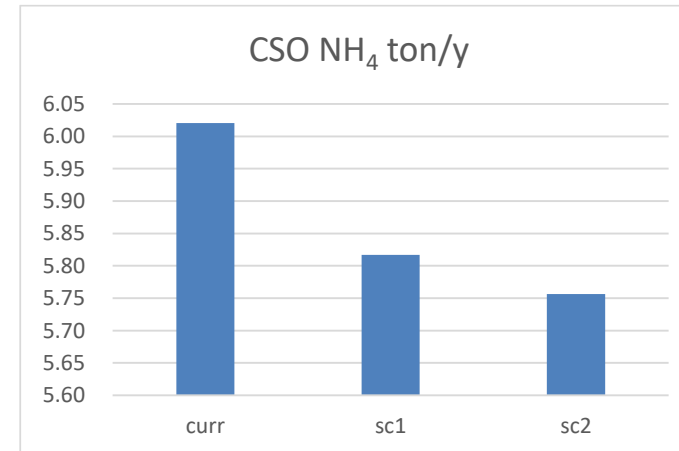
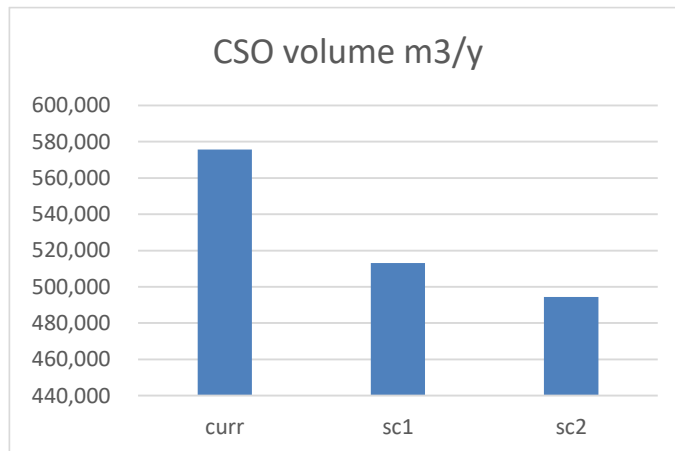



ODENSE SYSTEM OPEX (50% INFILTRATION REDUCTION)

Odense modeled OPEX (Annual \$k)

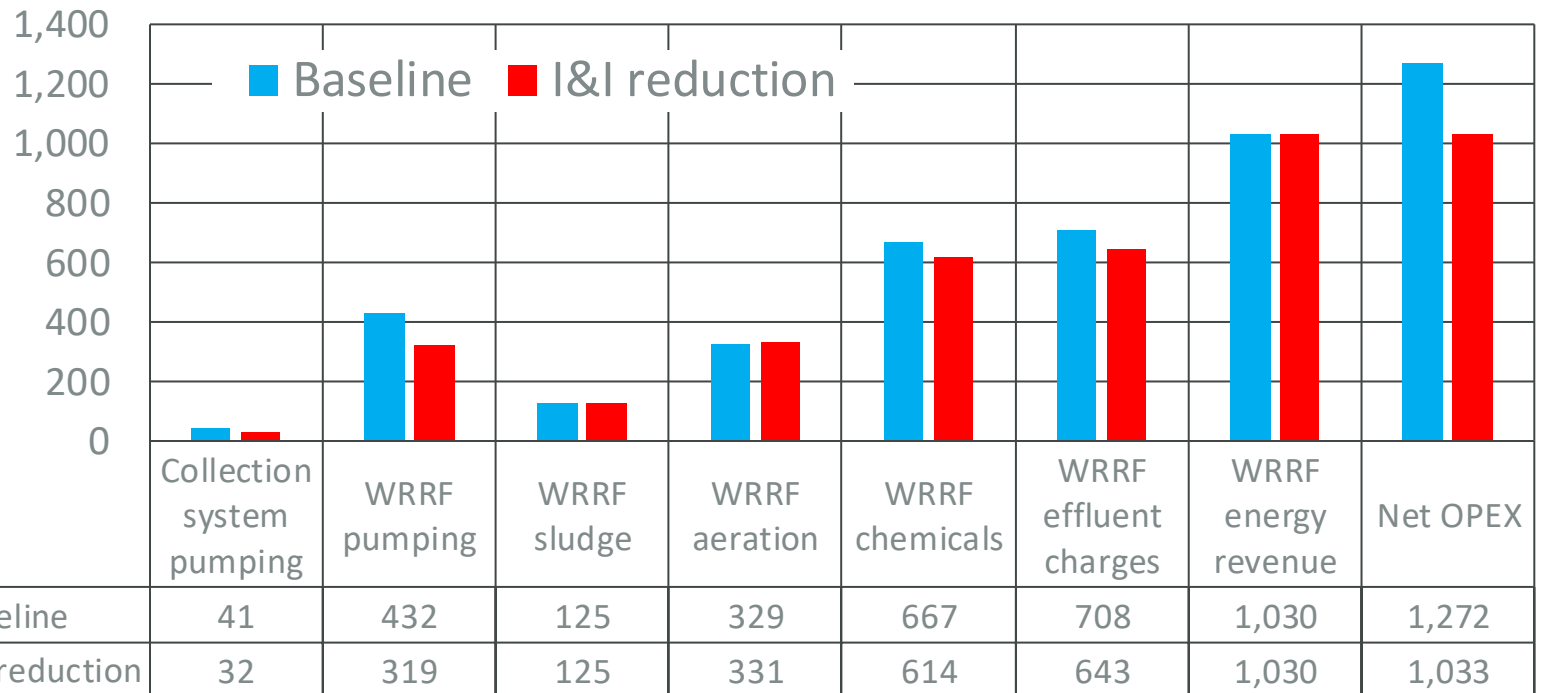



WATER QUALITY (NH₄) AT MOST IMPACTED RIVER SECTION

baseline

1	3	1	0.0	16.2	2.9
1	1	1	0.0	0.0	0.0
1	1	1	0.0	0.0	0.0

50% infiltration
reduction

1	3	1	0.0	16.2	4.4
1	1	1	0.0	0.0	1.5
1	1	1	0.0	0.0	0.0

More frequent exceedance of long duration ammonia standards because of:

1. Reduced flow in sewer =>
2. greater sedimentation in sewer =>
3. increase in COD to be oxidised in wet weather =>
4. reduced aeration capacity =>
5. more frequent NH₄ peaks in effluent & river



IMPACT OF CSOS AND SSOS REMOVALS

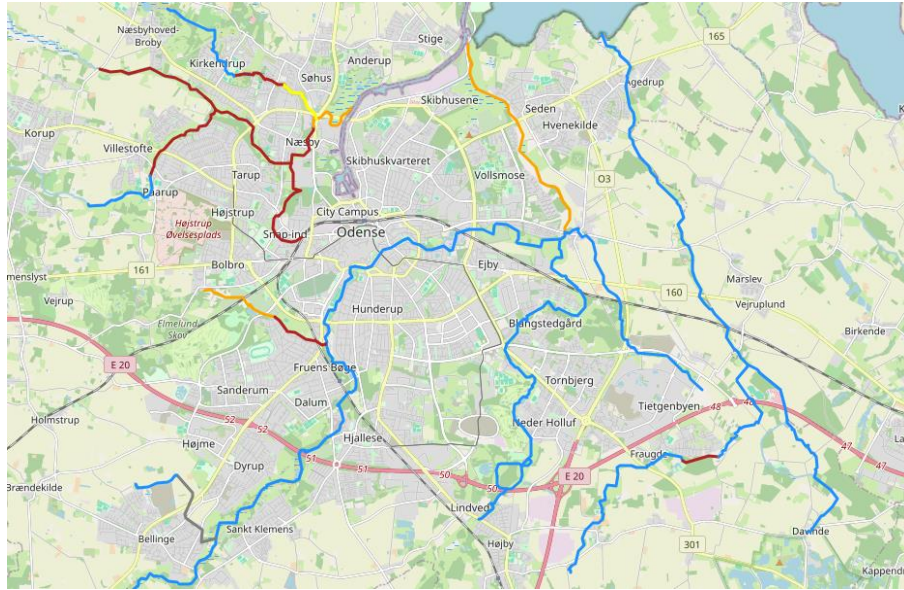

Status simulation

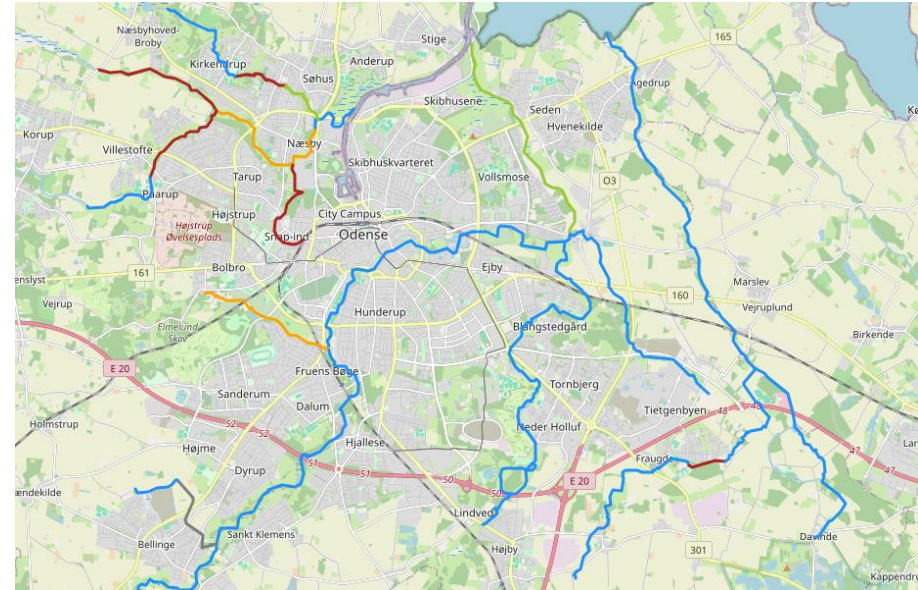

All CSOs and SSOs removed



IMPACT OF RESIDENTIAL DEVELOPMENT ON LOCAL CSOS

Increase from 2000 to 3900 inhabitants in one catchment

	pre	post	difference
CSO m ³ /y	33,122	35,784	+8%
COD kg/y	2,575	4,600	+79%
NH ₄ kg/y	95	200	+110%

Easily available impact on WWTP effluent and on river quality



CALCULATION OF SEWAGE FRACTION IN CSOS

- Calculated for all CSOs in the system
- Range from 0.1% to 18.3%
- Flow weighted average: 4.9%



OTHER USES

- Micropollutants fate (Cu)
- Quarterly reporting on unmonitored flows and loads from CSOs
- Support production of plans for new discharge permits for specific river stretches